

C7061A Dynamic Self-Check Ultraviolet Flame Detector

PRODUCT DATA



APPLICATION

The C7061A is a dynamic self-checking flame detector for sensing the ultraviolet radiation generated by the combustion of gas, oil, or other fuels.

FEATURES

- Oscillating shutter interrupts ultraviolet radiation reaching the UV sensor 12 times per minute to provide the UV sensor tube checking function. Amplifier circuitry components are checked from the microprocessor in the 7800 Series Control.
- Detectors can be mounted horizontally, vertically or at any other angle. The self-checking C7061 models require faceplate alignment and have integral locating reference points to assure proper shutter mechanism operation.
- Ultraviolet radiation sensing tube and quartz viewing window are field replaceable.
- Threaded conduit fitting and color-coded leadwires allow rapid electrical installation.
- C7061A1038 uses Brad Harrison® 41310 connector.
- Two flame detectors can be wired in parallel to reduce nuisance shutdowns in difficult flame sighting applications.
- A swivel mount is available to facilitate flame sighting.
- -40°F (-40°C) rated ultraviolet sensing tube.
- Incorporates UV sensor tube checking feature; used with R7861 Dynamic Self-check Amplifiers.
- High pressure 50 psi (345 kPa) quartz viewing window, magnifying lens and antivibration mount are available as accessories.
- Housing meets NEMA 4 enclosure standards.
- Protective heat block built into mounting flange.

Contents

Application	1
Features	1
Specifications	2
Ordering Information	2
Installation	3
Wiring	7
Adjustments and Checkout	8
Troubleshooting	9
Service	10



SPECIFICATIONS

IMPORTANT

The specifications in this publication do not include normal manufacturing tolerances. Therefore, this unit may not exactly match the specifications listed. This product is tested and calibrated under closely controlled conditions, and minor differences in performance can be expected if those conditions are changed.

Model:

C7061A Dynamic Self-Check Ultraviolet Flame Detector.

Electrical Ratings:

Voltage and Frequency:

The C7061 is powered from the Flame Safeguard unit that delivers the necessary voltages to operate the tube and shutter. Nominal voltage: (-15%, +10%), 50/60 Hz.

Ambient Operating Temperature Ratings

(Outside the Case):

-40°F to 175°F (-40°C to 80°C) using part no. 129464N UV Sensing Tube.

Storage Temperature Ratings:

-60°F to 175°F (-50°C to 80°C).

Housing:

Violet, cast-aluminum cover.

Separate mounting flange (with heat block) and faceplate provide heat insulation and sealoff.

Meets NEMA 4 enclosure requirements (indoor, outdoor protection; rain-tight, dust-tight, hose-directed water protection).

Optional water jacket available; see Accessories.

Pressure Rating of Quartz Viewing Window:

20 psi (138 kPa), see Replacement Parts.

Pressure Rating of Quartz Focusing Lens:

20 psi (138 kPa), see Accessories.

Mounting:

Mounting flange with 3/4 NPT internal threads for attaching to sight pipe.

Wiring Connections:

Leadwire: NEC Class 1 color coded.

Length: 8 ft (2.4m).

Threaded Leadwire Faceplate Opening: 1/2-14 NPSM internal threads for attaching conduit.

Connector: Brad Harrison® 41310.

Dimensions:

See Fig. 1.

Weight:

2.6 lbs (1.2 kg).

Serviceability:

Field replaceable ultraviolet sensing tube viewing window, coil and shutter assembly gaskets.

Approvals:

Underwriters Laboratories Inc. Listed: File Number MP268, Guide Number MCCZZ.

Canadian Standards Association Certified: Master File LR95329-1.

Factory Mutual Approved: 14740.01.

Industrial Risk Insurers Acceptable.

Replacement Parts:

129464N Ultraviolet Sensing Tube; -40°F (-40°C).

114372 Quartz Viewing Window; rated for 20 psi (138 kPa).

114465 Gasket, silicone rubber; for installing viewing window (three required).

120739 Gasket, fiber-neoprene; heat insulation and seal-off for mounting flange.

190971B Coil and Shutter Assembly.

ORDERING INFORMATION

When purchasing replacement and modernization products from your TRADELINE® wholesaler or distributor, refer to the TRADELINE® Catalog or price sheets for complete ordering number, or specify—

1. Model number.
2. Replacement parts, if required.
3. Accessories, if required.

If you have additional questions, need further information, or would like to comment on our products or services, please write or phone:

1. Your local Home and Building Control Sales Office (check white pages of your phone directory).
2. Home and Building Control Customer Logistics
Honeywell Inc., 1885 Douglas Drive North
Minneapolis, Minnesota 55422-4386 (612) 951-1000

In Canada—Honeywell Limited/Honeywell Limitée, 155 Gordon Baker Road, North York, Ontario M2H 2C9.

International Sales and Service Offices in all principal cities of the world. Manufacturing in Australia, Canada, Finland, France, Germany, Japan, Mexico, Netherlands, Spain, Taiwan, United Kingdom, U.S.A.

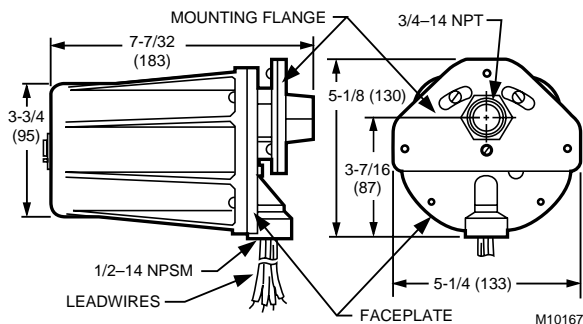

Fig. 1. Dimensions of C7061A in in. (mm).

Accessories:

- 118367A Swivel Mount.
- 122748 Quartz Viewing Window, rated for 50 psi (345 kPa).
- 124204 Quartz Focusing Lens, rated for 20 psi (138 kPa); increases the detector-sensed ultraviolet radiation.
- 120934 Mounting Flange, aluminum, with 3/4 inch NPT internal threads for attaching to sight pipe.
- 124198 Mounting Flange, aluminum, with 1 inch NPT internal threads for attaching to sight pipe.
- 123539 Antivibration Mount.
- 190105 Water Jacket.
- 204341 Mirror Assembly.

INSTALLATION

When Installing this Product...

1. Read these instructions carefully. Failure to follow them could damage the product or cause a hazardous condition.
2. Check the ratings given in the instructions and on the product to make sure the product is suitable for your application.
3. Installer must be a trained, experienced flame safeguard service technician.
4. After installation is complete, check out product operation as provided in these instructions.



CAUTION

Equipment damage hazard.
Sensing tube can fail to discriminate between flame conditions.
 Change sensing tube after 40,000 hours of continuous use.



WARNING

Electrical shock hazard.
Can cause serious injury or death.

IMPORTANT

Disconnect power supply before beginning installation to prevent electrical shock and equipment damage. More than one disconnect may be involved.

1. Do not connect these detectors to non-Honeywell manufactured controls (primaries, programmers, multiburner systems, and burner management systems). Unsafe conditions could result.
2. All wiring must be NEC Class 1 (line voltage).
3. Voltage and frequency of the power supply connected to this detector must agree with the values marked on the detector.
4. Sight the detector so it does not respond to ignition spark.
5. On multiburner installations, each detector must respond only to the flame of the burner it is supervising.
6. Do not connect more than two C7061A Flame Detectors in parallel.

Proper flame detector installation is the basis of a safe and reliable flame safeguard installation. Refer also to the burner manufacturer instructions. Carefully follow all instructions for the best possible flame detection application.

Basic Requirements

The combustion flames of most carbon-based fuels emit sufficient ultraviolet radiation to enable the C7061 Solid State (Purple Peeper) Ultraviolet Flame Detector to prove the presence of a flame in a combustion chamber. The detector is mounted outside the combustion chamber with its mounting flange or union threaded to one end of a sight pipe inserted through the wall of the combustion chamber. The ultraviolet sensing tube in the flame detector sights the flame through the pipe.

When a flame is present, the UV tube in the C7061 senses the ultraviolet radiation emitted. The C7061 then produces a signal that is sent to the amplifier in the flame safeguard control. The amplified signal pulls the flame relay into the control to allow proper system operation.

Because it is necessary for the UV sensing tube to actually see the flame, it is best to locate the detector as close to the flame as physical arrangement, temperature, and other restrictions permit. These restrictions are described in detail in the following paragraphs.

Determine Location

Before beginning the actual installation, determine the best location for mounting the detector. Carefully consider the factors discussed in this section before deciding on the location.

Temperature

Install the C7061 where the ambient temperature (outside the case) stays within the ambient operating temperature ratings.

To keep the C7061 below its maximum rating, it may be necessary to add additional insulation between the wall of the combustion chamber and the detector. A shield or screen can be added to reflect radiated heat away from the detector. If the detector continues to get too hot, cooling is necessary. Refer to the Sight Pipe Ventilation section. (A 190105 Water Jacket is also available for cooling the C7061.)

Vibration

If the C7061 is subject to excessive vibration, use a special 123539 Antivibration Mount. If you use this mount, install it before you position and sight the detector.

Clearance

Make sure there is enough room to easily mount the sight pipe, detector, and all required fittings, and to remove the detector for troubleshooting and servicing.

Radiation Sources (Other than Flame)

Examples of radiation sources (other than flame) that could actuate the detection system:

Ultraviolet sources:

Hot refractory above 2300°F (1260°C).

Spark:

- Ignition transformers.
- Welding arcs.
- Lightning.

Welding flames.

Bright incandescent or fluorescent artificial light.

Solar radiation.

Gas lasers.

Sun lamps.

Germicidal lamps.

Bright flashlight held close to the sensing tube.

Gamma ray and X-ray sources:

Diffraction analyzers.

Electron microscopes.

Radiographic X-ray machines.

High voltage vacuum switches.

High voltage condensers.

High voltage coronas.

Radioisotopes.

Except under unusual circumstances, none of these sources except hot refractory and ignition spark would be present in or near the combustion chamber.

The detector *can* respond to hot refractory above 2300°F (1260°C) if the refractory surface represents a significant percentage of the detector field of view. If the temperature of the hot refractory causes the flame relay (in the flame safeguard control) to pull in, re-aim the sight pipe so the detector views a cooler area of the refractory.

Ignition spark is an intense source of ultraviolet radiation.

When installing the detector, make sure it does not respond to ignition spark.

Single Burner Requirements

The detector must have an unobstructed view of a *steady* part of the flame it is supervising. This requires a proper sighting angle and minimized ultraviolet radiation attenuation effects. However, when supervising only one burner, sighting requirements are simplified.

Sighting Angle (Fig. 2)

The first 30 percent of a flame closest to the burner nozzle (the flame root) emits the most ultraviolet energy. Also, if the detector sights the flame at an angle instead of perpendicularly, it views more flame depth. Therefore, the best sighting angle is nearly parallel to the axis of the flame, permitting the detector to view a large portion of the first 30 percent of the flame closest to the burner nozzle, as illustrated in Fig. 2.

Low angle sighting permits the detector to view a greater depth of flame, thus reducing the effects of instabilities in the flame pattern. Also, the environment near the burner nozzle is usually cleaner than at any other part of the combustion chamber. This provides a clearer line of sight and can keep the viewing window cleaner, thus reducing the maintenance required.

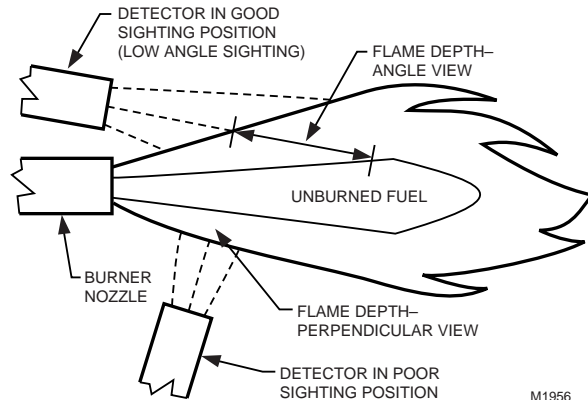

Fig. 2. Detector sighting angle.

NOTE: When possible, it is desirable to tilt the detector and sight pipe *downward* to prevent the buildup of soot in the pipe or on the viewing window.

In most installations, the detector needs to respond to the pilot flame alone, then the pilot and main burner flame together, and finally the main burner flame alone. The detector must meet all sighting requirements that apply:

- Pilot flame alone—the smallest pilot flame that can be detected must be capable of reliably igniting the main burner.
- Pilot and main burner flame together—the detector must sight the junction of both flames.
- Main burner flame alone—the detector must sight the most stable part of the flame for all firing rates.

Parallel Flame Detectors

Shifting flame patterns, commonly encountered on burners with high turndown ratios, can require two parallel detectors to prove the flame at the highest and lowest firing rates and for modulation in between. In this case, one detector supervises the pilot (interrupted) and both detectors supervise the main burner flame. During the main burner run period, either detector is capable of maintaining system operation. A maximum of two C7061 Detectors can be connected in parallel.

In addition to assuring more reliable flame detection, parallel detectors facilitate maintenance during burner operation. Each detector can be removed, in turn, without shutting down the supervised burner. However, a flame simulating failure occurring in the flame signal amplifier or in either detector will cause a shutdown.

Screening Effects

Smoke, oil mist, dirt and dust are masking agents that attenuate the ultraviolet radiation that the flame emits. If they absorb too much radiation, the amount of ultraviolet radiation reaching the detector is reduced. The flame signal can then become too low to hold in the flame relay, resulting in burner shutdown.

The problem can be eliminated by diluting the contaminants. A strong flow of air through the sight pipe will clear a viewing path through the attenuating material. Refer to the Sight Pipe Ventilation section.

It is also desirable to sight the detector at an area containing fewer masking agents such as near the burner nozzle or near the entrance of the combustion air. Increasing the viewing area of the detector by shortening the sight pipe or by increasing the diameter of the sight pipe also reduces the attenuating effects of masking agents.

Multiburner Requirements (Flame Discrimination)

In addition to meeting the requirements for a single burner, a multiburner installation requires discrimination between flames. *Flame discrimination* can be defined as locating all flame detectors so that each detector responds only to the flame of the burner it is supervising.

In multiple burner systems, not every detector can be positioned so its line-of-sight does not intercept flames from other burners. For example, this situation occurs in front-fired boiler-furnaces having more than one row of burners, or in multilevel opposed-fired furnaces where the burners face each other.

When planning such an installation, locate each flame detector so that it has the best possible view of the first 30 percent closest to the burner nozzle (the flame root) it is supervising, and the worst possible view of all other flames.

Fig. 3 illustrates a critical detector application problem that requires flame discrimination. Flame discrimination is accomplished for Detector A by repositioning it until the flame relay (in the flame safeguard control) does not respond to Flame B. Note that Detector A is aimed at the first 30 percent of Flame A where the ultraviolet radiation is most intense. It sights the *tip* of Flame B, but it is not aimed at the first 30 percent of Flame B where UV is intense. Detector A is repositioned to assure maximum response to Flame A while rejecting Flame B. Similarly, Detector B is positioned to assure maximum response to Flame B while rejecting Flame A.

If you reposition a detector and still cannot achieve flame discrimination, try reducing the viewing area by increasing the length or decreasing the diameter of the sight pipe, or adding an orifice plate.

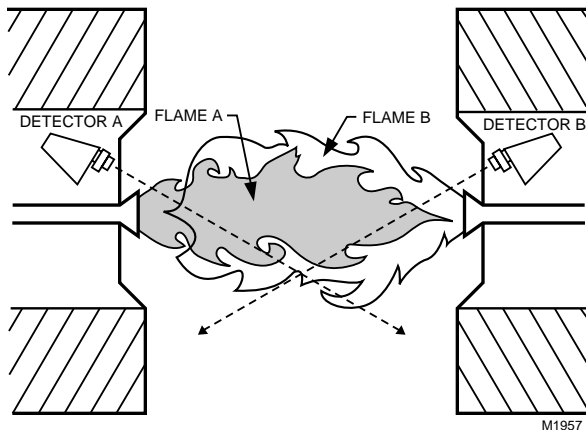
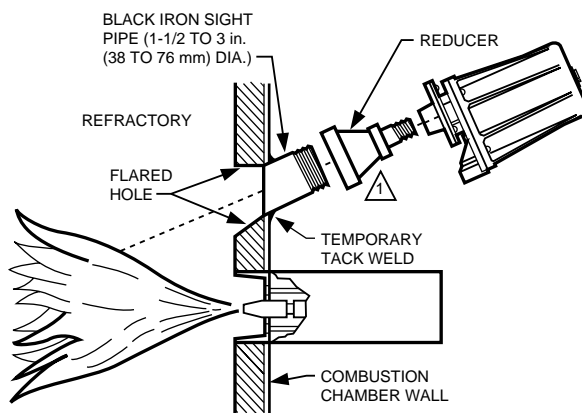

Fig. 3. Example of flame discrimination problem (opposed fired burners).

Install the Sight Pipe (Fig. 4)

After you have determined the location and sighting angle, select the sight pipe. A black iron pipe with a diameter of at least 1-1/2 in. (38 mm) is recommended. Do *not* use stainless steel or galvanized pipe because they reflect ultraviolet radiation internally and complicate aiming the pipe.

Sight pipes with diameters 2 to 3 in. (51 to 76 mm) produce better results for horizontal rotary burners, which require wide viewing angles. A wide viewing angle can also be obtained by using a short sight pipe.



1 IF VENTILATION OF THE SIGHT PIPE IS REQUIRED, ADD PIPE TEE, PERFORATED NIPPLE, OR OTHER SUITABLE DEVICE FOR VENTILATION.

M10125

Fig. 4. Typical mounting of C7061A.

Prepare Hole in Combustion Chamber Wall

Cut or drill a hole of the proper diameter for the sight pipe in the wall of the combustion chamber at the selected location. Flare the hole to leave room for small adjustments of the sighting angle. The taper of the hole should be about 1 in. for every 3 in. (25 mm for every 76 mm) of wall thickness.

Mount Sight Pipe

Thread one end of the pipe to fit the mounting flange, union, or required coupling. Cut the pipe to the desired length (as short as practical) and at an angle so it fits flush with the wall of the combustion chamber. Tack weld the pipe to the wall in a trial position. *Do not weld the sight pipe permanently in place until after completing the Adjustments and Checkout.*

NOTE: If you use 118367A Swivel Mount and you are *positive* about the location and sighting angle, you can permanently weld the pipe.

Install Fittings

In some cases, the sight pipe does not directly fit the C7061 mounting flange or union. Also, it may be desirable or necessary to ventilate the sight pipe. You may also want to use a swivel mount or an antivibration mount. Each of these cases can require additional fittings.

Reducer

For sight pipes of larger diameter than the mounting flange connector or union, install a reducer as illustrated in Fig. 4. The reducer requires a close nipple with 3/4 in. NPT external threads:

Sight Pipe Ventilation

It may be necessary to ventilate the sight pipe to cool the detector or to clear a viewing path through UV radiation attenuating material.

For a negative pressure combustion chamber, drilling a few holes in the section of the sight pipe outside of the combustion chamber allows air at atmospheric pressure to flow through the sight pipe and into the chamber. A perforated pipe nipple between the sight pipe and the detector can also be used.

For a positive pressure combustion chamber, connect a supply of pressurized air from the burner blower to flow through the sight pipe and into the chamber. The air pressure must be greater than the chamber pressure.

Swivel Mount

To facilitate proper flame sighting, use 118367A Swivel Mount (ordered separately). The swivel mount requires a reducer of the proper size to mount it onto the sight pipe. It also requires a one-inch close nipple for mounting to a C7061 with a one-inch connector. (For 118367A Swivel Mount mounting details, refer to 60-0361.)

Antivibration Mount

The detector withstands normal burner vibration. If the vibration is excessive, 123539 Antivibration Mount is available. (For mounting details, see form 60-0361.) If you use this mount, install it before positioning and sighting the detector.

Mount the Detector (Fig. 4-7)

Mount the detector onto the sight pipe, reducer, or other fitting (see Fig. 4-7).

The C7061 Self-Checking Flame Detectors incorporate an oscillating shutter mechanism and, therefore, require special consideration for mounting positions other than vertically sighting downward or upward, as illustrated in Fig. 5. The C7061 has notch and arrow indicators (see Fig. 6) on the faceplate to facilitate mounting in positions other than those shown in Fig. 5. The notch and arrow must be vertically aligned with the notch in the up position and the arrow pointing downward (see Fig. 6). The C7061 must be mounted with the conduit opening located approximately 45 degrees below the horizontal (see Fig. 6).

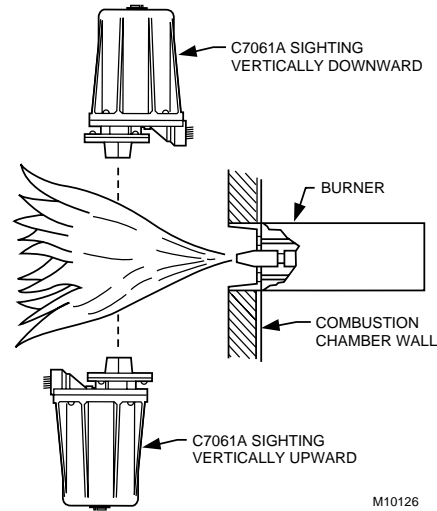

Fig. 5. Vertical mounting of C7061A.

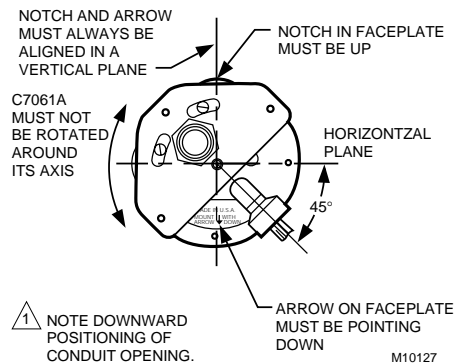
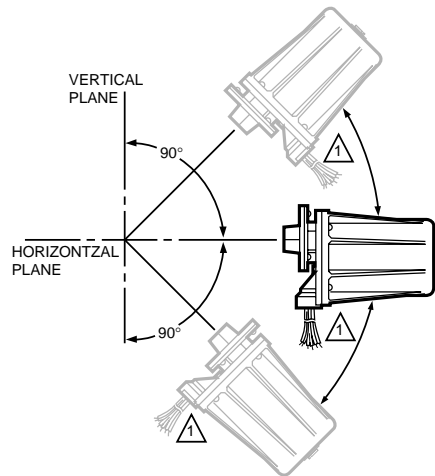

Fig. 6. C7061 mounting positions.

IMPORTANT

The notch and arrow on the faceplate must be aligned in a **vertical** plane with the notch **up** and the arrow pointing **down**.

The housing **must** be mounted with the conduit opening approximately **45° below horizontal** (see Fig. 6).

To mount a C7061A (Fig. 7):

1. The mounting flange is in two pieces. Loosen (but *do not* remove) the three screws holding the flange together.
2. Slightly rotate the detector so the slots in the back section of the mounting flange clear the screws in the front section; then separate the two sections.
3. Screw the front section of the mounting flange onto the sight pipe, reducer, or other fitting.

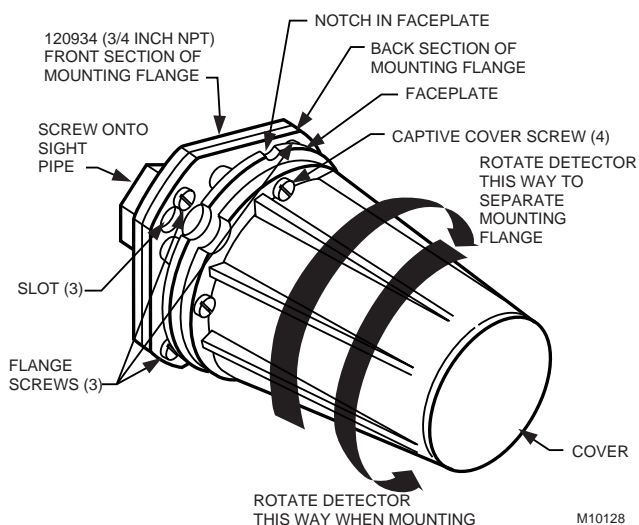

Fig. 7. Mounting C7061A Detector.

4. Fit the slots in the back section of the mounting flange (with the detector) over the three screws in the front section, and rotate the detector so the screws hold the flange together.
5. Tighten the screws securely.

WIRING (FIG. 8)**CAUTION**

Equipment damage hazard.
Improper wiring can permanently damage amplifier.

When using a C7061A with an R7861 Dynamic Self-Check Amplifier, be careful not to short the *white* shutter leadwires together (by wiring incorrectly, leaving an incorrect jumper wire, or stripping the insulation too much so the bare leadwires can touch).

1. All wiring must comply with applicable local electrical codes, ordinances, and regulations. Use NEC Class 1 wiring.
2. Keep the flame signal leadwires as short as possible from the flame detector to the terminal strip or wiring subbase. Capacitance increases with leadwire length, reducing the signal strength. The maximum permissible leadwire length depends on the type of leadwire and conduit type and diameter. *The ultimate limiting factor in flame signal leadwire length is the signal current.* Refer to Table 1.
3. The detector has color-coded plastic-insulated, no. 18 leadwires, 8 ft (2.4m) long, rated for 221°F (105°C). *These wires must be run in a conduit.*
4. If the leadwires are not long enough to reach the terminal strip or wiring subbase, make the required splices in a junction box.
5. If splicing is necessary, use moisture-resistant no. 14 wire suitable for at least 167°F (75°C) if the detector is used with a flame safeguard *primary* control, or at least 194°F (90°C) if used with a flame safeguard *programming* control.
6. *For high temperature installations*, use Honeywell specification no. R1298020 wire or equivalent for the F leadwire. This wire is rated up to 400°F (204°C) for continuous duty. It is tested for operation up to 600 volts and for breakdown up to 7500 volts. For the other leadwires, use moisture-resistant no. 14 wire selected for a temperature rating above the maximum operating temperature.
7. Refer to Fig. 8 for wiring connections.

IMPORTANT

Do not run the flame detector wiring in the same conduit with high voltage ignition transformer wires.

Connecting Detectors in Parallel

For a flame that is difficult to sight, using two parallel C7061 Flame Detectors reduces nuisance shutdowns. If only one of the parallel detectors loses the flame signal, the other indicates the presence of the flame and keeps the burner running. *When two parallel C7061A Detectors are used, a flame-simulating failure in either detector causes the burner to shut down.* Two C7061A Detectors can be connected in parallel to the same terminals on 120 volt flame safeguard controls. To avoid exceeding the rating of the solid-state shutter switch in the R7861 Flame Signal Amplifier, *do not connect more than two C7061A Detectors in parallel.*

IMPORTANT

Voltage and frequency rating of the C7061A must match the power supply of the flame safeguard control.

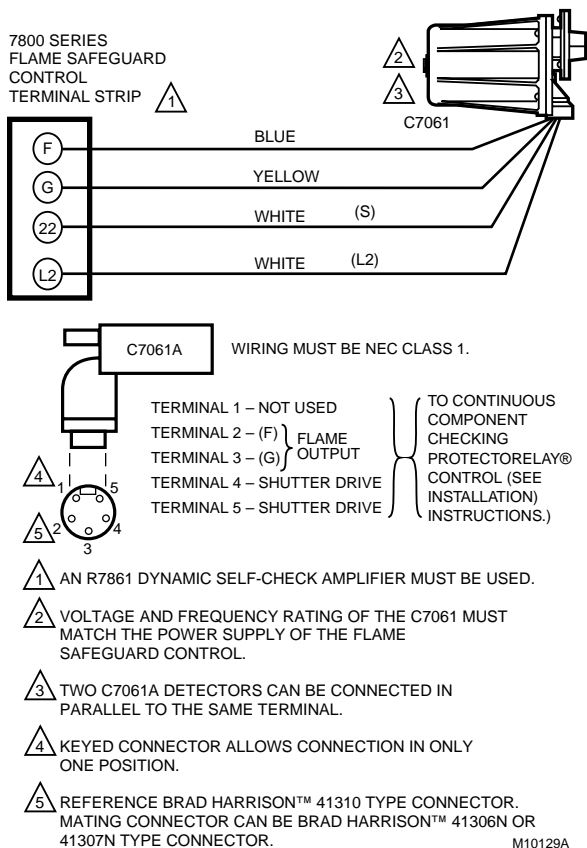

Fig. 8. Wiring diagram for C7061A Detectors with 7800 Series Flame Safeguard controls with shutter drive circuitry.

ADJUSTMENTS AND CHECKOUT

UV Sensor Tube Test

For initial burner lightoff, consult the burner manufacturer instructions or the flame safeguard control instructions.

If the system does not start during the initial burner lightoff, check the UV sensor tube in the flame detector. If a reddish glow appears when there is no flame present, replace the UV sensing tube. When performing this test, make sure there are no extraneous sources of ultraviolet radiation in the test area (see Radiation Sources section).

Adjust Detector Sighting

With the flame detector installed and the burner running, adjust the sighting position of the detector for optimum flame signal.

It is suggested that a volt-ohm meter with a minimum sensitivity of one megohm/volt and a zero to five or ten Vdc scale be used for R7861 Amplifier flame signal measurements. Measure the flame signal as illustrated in Fig. 9. Be careful to make the proper connections of positive (red) meter lead to positive (+) control jack and negative (black) meter lead to negative (-) or (-Com) jack with 7800 SERIES controls. When the 7800 SERIES control has a Keyboard Display Module, a zero to five Vdc voltage is displayed on the module.

NOTES:

1. The shutter operation causes fluctuations in the voltage reading. Read the average stable reading, disregarding the peaks.
2. The flame signal must be steady (or stable as described in NOTE 1).

Move the detector and sight pipe around to sight the flame from various positions and angles. Try to get a maximum steady (or stable) reading on the meter that is above the minimum acceptable voltage listed in Table 1.

Measure the flame signal for the pilot alone, the main burner flame alone, and both together (unless monitoring only the pilot flame when using an intermittent pilot, or only the main burner flame when using direct spark ignition). Also measure the flame signal at low and high firing rates and while modulating in between (as applicable). With the detector in its final position, all required flame signals must be steady (or stable) and as specified in Table 1. If you cannot obtain the proper signal, refer to the Troubleshooting section.



Fig. 9. Measuring voltage flame signal with 7800 SERIES controls.

Pilot Turndown Test

When the detector is used to prove a pilot flame before the main fuel valve(s) can be opened, perform a Pilot Turndown Test before welding the sight pipe into position. Follow the procedures in the flame safeguard control instructions and in the burner manufacturer instructions.

Table 1. Flame Signal.

Flame Detector	Plug-in Flame Signal Amplifier	Flame Safeguard Control(s)	Minimum ^a Acceptable Steady Voltage (Vdc)	Maximum Expected Voltage (Vdc)
C7061A	R7861 Dynamic Self-Check ^{a,b}	RM7800E,G,L,M; RM7823A; RM7838A,B; EC7823A; RM7840E,G,L,M; RM7890B; EC7890A,B; RM7895A,B,C,D; EC7895A,C; EC7885; EC7810; EC7820; EC7830; EC7850.	1.25	5.0

^a Shutter operation of the C7061A causes fluctuations in the voltage reading. Read the average stable voltage, disregarding the peaks.

^b Shutter operates at 12 cycles per minute.

Ultraviolet Response Tests Ignition Spark Response Test

Test to be sure that ignition spark is not actuating the flame relay in the flame safeguard control.

1. Close the pilot and main burner manual shutoff valves.
2. Start the burner and run through the Ignition period. Ignition spark should occur, but the flame LED must not light. The flame signal should not be greater than 0.25 Vdc.
3. If the flame relay does pull in, reposition the detector farther from the spark, or relocate/resight the detector to eliminate/reduce the detector response to reflected UV radiation. It may be necessary to construct a barrier to block the ignition spark from the detector view. Continue adjustments until the flame signal due to ignition spark is less than the flame signal values indicated in step 2.

Response to other Ultraviolet Radiation Sources

Some sources of artificial light produce small amounts of ultraviolet radiation. Under certain conditions, an ultraviolet detector responds as if it is sensing a flame. *Do not use an artificial light source to check the response of an ultraviolet flame detector.* To check for proper detector operation, conduct flame failure response tests under all operating conditions.

Weld the Sight Pipe

When the flame signal is acceptable after all adjustments are made, remove the detector and weld the sight pipe in its final position. (If you are using a swivel mount, the pipe may be already welded.) Then reinstall the detector.

Final Checkout

Before putting the burner into service, check out the installation using the Checkout procedures in the Instructions for the appropriate flame safeguard control. After completing the Checkout, run the burner through at least one complete cycle to verify correct operation.

IMPORTANT

Do not put the system into operation until all Checkout tests in the Instructions for the appropriate flame safeguard control and any others specified in the burner installation instructions are satisfactorily completed.

TROUBLESHOOTING

WARNING

Electrical shock hazard.

Can cause serious injury or death.

Open the master switch to disconnect power before removing or installing the detector or its cover. More than one disconnect may be involved.

Equipment Required

A volt-ohm meter with a minimum sensitivity of one megohm/volt and a zero to five or ten Vdc scale is suggested. When the Keyboard Display Module is included with the control, a flame signal displays on the module.

For replacement parts, see Specifications section.

UV Sensor Tube Test

See UV Sensor Tube Test section.

Unsatisfactory Flame Signal

If a satisfactory flame signal (see Table 1) cannot be obtained while adjusting the sighting position of the detector, follow these procedures. If you encounter other problems in the system, refer to the Troubleshooting section in the instructions for the appropriate flame safeguard control.

NOTE: For instructions to replace the viewing window, sensing tube, and coil and shutter assembly, see the Service section.

Troubleshooting Procedures

First perform the Preliminary Inspection. Then follow the applicable procedures for either a low meter reading or a zero meter reading. After reinstalling the detector or replacing its cover, recheck the meter reading. To try to obtain the proper flame signal, adjust the position of the detector. If you complete all of the procedures and yet cannot obtain a proper flame signal, replace the detector.

Preliminary Inspection

1. Check for the proper line voltage. Make sure the master switch is closed, connections are correct, and power supply is of the correct voltage and frequency.
2. Check the detector wiring for defects:
 - a. Incorrect connections.
 - b. Wrong type or size of wire.
 - c. Deteriorated wire.
 - d. Open circuits.
 - e. Short circuits.
 - f. Leakage paths caused by moisture, soot, or dirt.
3. With the burner running, check the temperature at the detector. If it exceeds 175°F (79°C):
 - a. Add additional insulation between the wall of the combustion chamber and the detector.
 - b. Add a shield or screen to reflect radiated heat away from the detector, or
 - c. Add cooling (refer to Sight Pipe Ventilation and Accessories sections).

Removing Detector from Sight Pipe (Refer to Fig. 7)

Loosen the three screws holding the mounting flange; rotate the detector slightly so the screws clear the slots in the back section of the flange; separate the flange; and pull off the back section (with the UV sensor).

NOTE: The detector is free when the collar is unscrewed; *do not drop it.*

Procedure for Zero Meter Reading

1. Replace the plug-in amplifier. Then recheck the flame signal.
2. Replace the ultraviolet sensing tube (see Service section). Then recheck the flame signal.
3. Replace the coil and shutter assembly (see Service Section). Then recheck the flame signal.
4. If you cannot yet obtain a meter reading, replace the detector.

IMPORTANT

At the completion of Troubleshooting, be sure to perform the Adjustments and Checkout procedures.

SERVICE

⚠ WARNING

Electrical shock hazard.

Can cause serious injury or death.

Open the master switch to disconnect power before removing or installing the detector or its cover. More than one disconnect can be involved.

Periodic Maintenance

1. Clean the viewing window (or focusing lens) when necessary. Remove the detector (see Troubleshooting section) and use a clean cloth over the eraser end of a pencil. Do not remove the window (or lens) to clean it. If it is broken or damaged or it is coated with a substance that cannot be removed, replace it (see Fig. 13).

2. Keep the flame detection system adjusted for the smoothest, most reliable operation as recommended by the burner manufacturer.
3. Replace the sensing tube, coil and shutter assembly, or viewing window only when necessary *to obtain proper operation.*

Removing Detector Cover (All Models):

1. Open the Master Switch.
2. Unscrew the four captive cover screws (Fig. 7) and carefully slide off the cover.

NOTE: These bolts are removable. Put them in a safe place to avoid losing them.

Replacing Ultraviolet Sensing Tube (All Models) (Fig. 11)

IMPORTANT

Be very careful not to kink or otherwise damage the flexible shutter.

1. *Open the master switch* and remove the cover from the detector (see instructions above).
2. Locate the UV sensing tube.
3. Gently bend the alignment guide just enough to free the tip of the tube.
4. Insert a screwdriver between the tube base and the socket, and gently pry the tube out of its socket.
5. Pull the tube completely out of its socket.
6. Insert the new tube through the openings in the shutter assembly.
7. Align the three pins on the new tube with the holes in the socket.
8. Carefully push the new tube firmly into the socket until the alignment guide snaps into place around the tip of the tube.
9. Make sure the new UV sensor tube is seated securely.
10. Replace the detector cover.

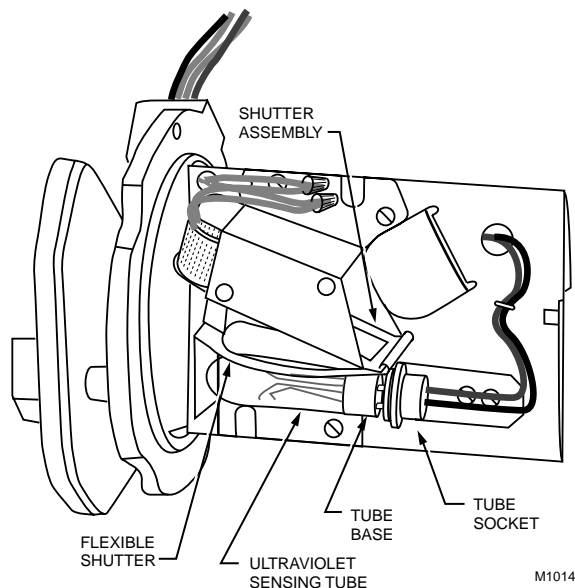

M10141

Fig. 11. Replacing ultraviolet radiation sensing tube.

Replacing Coil and Shutter Assembly (Fig. 12)

NOTE: Use *only* a 190971B Coil and Shutter Assembly.

1. *Open the master switch* and remove the detector cover (see Removing Detector Cover section).
2. Remove the ultraviolet sensing tube (steps 1 through 5 of Replacing Ultraviolet Sensing Tube section).
3. Cut the white wires as close as possible to the crimped connectors, and remove the crimped connectors.
4. Remove the three mounting screws from the base of the coil and shutter assembly. Put the screws in a safe place.
5. Remove the coil and shutter assembly.
6. Install the new coil and shutter assembly.

IMPORTANT

Be very careful not to kink or otherwise damage the flexible shutter.

7. Insert the three mounting screws into the base of the coil and shutter assembly and tighten securely.
8. Remove sufficient insulation from each of the two white leadwires remaining on the detector, and also from each of the two white leadwires on the new coil.
9. Using solderless connectors, connect one of the coil wires to one of the remaining white leadwires. Connect the other coil wire to the other remaining white leadwire.
10. Reinstall the sensing tube (steps F through I of Replacing Ultraviolet Sensing Tube section).
11. Replace the detector cover.

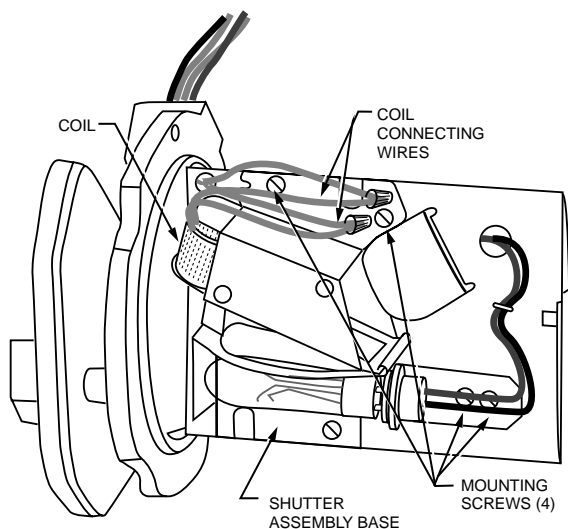

M10142

Fig. 12. Replacing coil and shutter assembly.

Replacing Quartz Viewing Window (or Focusing Lens) (See Fig. 13)

IMPORTANT

Use quartz window or lens. Ordinary glass absorbs or filters out ultraviolet radiation.

1. *Open the master switch*; remove the detector from the sight pipe and remove the detector cover. (See appropriate sections.)
2. Remove the ultraviolet sensing tube (steps 1 through 5 of Replacing Ultraviolet Sensing Tube section).
3. Loosen the three screws holding the back section of the mounting flange to the faceplate. Carefully remove and *keep together the three screws, the gray asbestos-neoprene gasket, the red rubber washer, and the back section of the mounting flange.*

NOTE: If the viewing window (with its rubber mounting gaskets) is stuck to the mounting flange, skip step 4.

IMPORTANT

Be very careful not to kink or otherwise damage the flexible shutter.

4. Using the eraser end of a pencil, push out the viewing window (with its rubber mounting gaskets) from the inside of the faceplate.
5. Insert one rubber mounting gasket into the window aperture in the faceplate.
6. Insert the new quartz viewing window (or focusing lens) into the window aperture with either side toward the flame.

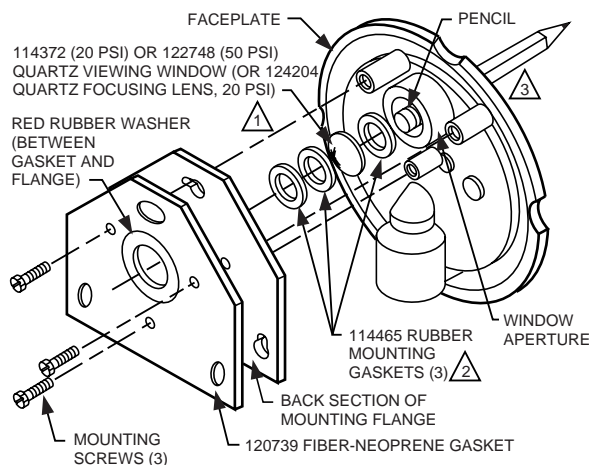

1 VIEWING WINDOW CAN BE REPLACED WITH EITHER SIDE TOWARD THE FLAME.

2 ONLY ONE GASKET ON EACH SIDE OF THE FOCUSING LENS.

3 REMOVE THE THREE MOUNTING SCREWS AND MOVE THE COIL AND SHUTTER ASSEMBLY OUT OF THE WAY TO PUSH OUT THE VIEWING WINDOW.

M10130

Fig. 13. Replacing quartz viewing window or focusing lens.

7. Insert two rubber mounting gaskets (only one gasket when replacing a focusing lens) into the aperture.
8. Put the back section of the mounting flange, red rubber washer, and fiber-neoprene gasket in place on the faceplate, and securely tighten the three mounting screws.
9. Clean both sides of the viewing window (or focusing lens) using a clean cloth placed over the eraser end of a pencil.
10. Reinstall the sensing tube (steps F through I of Replacing Ultraviolet Sensing Tube section).
11. Replace the detector cover and reinstall the detector on the sight pipe.

NOTE: Make sure the red rubber washer between the gray fiber-neoprene gasket and the back section of the mounting flange does not protrude over the window aperture or otherwise obscure the detector line-of-sight.

Home and Building Control

Honeywell Inc.
Honeywell Plaza
P.O. Box 524
Minneapolis MN 55408-0524

Honeywell Latin American Division

Miami Lakes Headquarters
14505 Commerce Way Suite 500
Miami Lakes FL 33016

Home and Building Control

Honeywell Limited-Honeywell Limitée
155 Gordon Baker Road
North York, Ontario
M2H 2C9

Honeywell Europe S.A.

3 Avenue du Bourget
B-1140 Brussels Belgium

Honeywell Asia Pacific Inc.

Room 3213-3225
Sun Hung Kai Centre
No. 30 Harbour Road
Wanchai
Hong Kong

Honeywell

